



VTC-IRE70/650 **Day/Night Infrared 700 TV Line Bullet** **Camera w/300' Range**



- High Density 1/3" Sony EXVIEW CCD & Effio-E DSP
- 700TVL High Resolution
- E-WDR by Adaptive Tone Reproduction
- 70 Infrared LEDs at 840nm enable viewing in total darkness up to 300 feet
- Infrared LED Dynamic Intensity Control with Automatic Brightness Adjustment of IR LEDs to help prevent washed out images when objects are too close
- Camera and IR LED compartments are separated using a dual glass design to prevent stray IR light from entering the lens
- Vari-Focal 6-50mm DC Auto Iris IR Lens
- 0.003 Lux (F1.2 @ 40IRE) / 0 Lux with IR LEDs On
- 2DNR Noise Reduction
- True Day/Night by ICR - Infrared Cut Removal
- Secondary Video Output & OSD Control Joystick are accessible inside a gasket sealed removable side panel
- Gasket-sealed external focus and zoom controls with clutch mechanism to eliminate over-tightening for ease of installation and adjustment
- Heavy Duty IP68 rated weather/vandal resistant aluminum construction is 100% water and dust proof
- Motion Detection
- Privacy & Highlight Masking
- OSD (On Screen Display) menu and Camera ID
- 24VAC/12VDC Dual Voltage

VITEK

1. Safety Instructions and Notes.....	2
2. General Descriptions	2
3. Supplied Items.....	3
4. Part names	4
5. Installation Instructions.....	5
5.1. Mounting The Camera	5
5.2. Power Supply Connections.....	5
6. Setup Menu.....	5
6.1 In the Menu	5
6.2 Main Menu	6
6.2.1 Main Menu-1	6
6.2.2 Main Menu-2	7
6.3 Shutter/AGC Menu.....	7
6.3.1 Shutter/AGC> Auto Setup Menu	8
6.3.2 Shutter/AGC> Manual Setup Menu	9
6.4 Lens Menu	9
6.5 Day/Night Menu	10
6.6 Picture Adjust Menu.....	11
6.7 White Balance Menu	12
6.8 ATR (Adaptive Tone Reproduction) Menu.....	13
6.9 Backlight Menu.....	14
6.10 NR Menu.....	14
6.11 Motion Detection Menu	15
6.12 Privacy Menu.....	16
6.13 Language Menu	16
6.14 Camera ID Menu	17
6.15 Camera Reset.....	17
6.16 EXIT	17
7. Specifications	18
8. Dimensional Drawings.....	19
Warranty.....	21

WARNING



This symbol is intended to alert the user to the presence of important operating and maintenance (servicing) instructions in the literature accompanying the unit.



This symbol is intended to alert the user to the presence of un-insulated "dangerous voltage" within the product's enclosure that may be of sufficient magnitude to constitute a risk of electric shock.

	CAUTION RISK OF ELECTRIC SHOCK DO NOT OPEN	
CAUTION: TO REDUCE THE RISK OF ELECTRIC SHOCK, DO NOT REMOVE COVER (OR BACK). NO USER SERVICEABLE PARTS INSIDE. REFER SERVICING TO QUALIFIED SERVICE PERSONNEL.		

Caution To prevent electric shock and risk of fire hazards, do NOT use other than specified power source.
--

Warning (NTSC version) -- This equipment has been tested and found to comply with the limits for a Class A digital device, pursuant to part 15 of the FCC Rules. These limits are designed to provide reasonable protection against harmful interference when the equipment is operated in a commercial environment. This equipment generates, uses, and can radiate radio frequency energy and, if not installed and used in accordance with the instruction manual, may cause harmful interference to radio communications. Operation of this equipment in a residential area is likely to cause harmful interference in which case the user will be required to correct the interference at his/her own expense.

Caution -- Any changes or modifications in construction of this device that are not approved by the party responsible for compliance could void the user's authority to operate the equipment.

1. Safety Instructions and Notes

- Please read these safety and operating instructions before operating the camera.
- Keep the manual in a safe place for later reference.
- Pay attention to safety when laying the connection cable and observe that the cable is not subjected to heavy loads, kinks, damage or moisture.
- Never open the device to expose boards or lenses. The warranty becomes void if repairs are undertaken by unauthorized persons.
- Only authorized service centers may perform maintenance or repairs.
- Use only a mild detergent to clean the housing.
- Keep the window surface clean of dirt or dust, which may reflect infrared light into the lens at night.
- The camera should never be operated in an environment that exceeds the technical specifications, as this may result in the destruction of the product and will also void the factory warranty.

2. General Descriptions

The VTC-IRE70/650 camera is an ultra clear resolution camera that realizes over 700TVL resolution and a crisp color reproduction with Sony 960H EX-view CCD and Effio-E image signal processor.

Effio-E digital imaging system:

- Delivers crystal clear images with 700TVL resolution that accurately captures every aspect of any scene
- Color signal processing provides the optimum balance between the luminance and chroma signals for high color reproducibility even for the detailed scenes that contain very high spatial frequency
- Incorporates 2D noise reduction signal processing

ICR mechanism:

- Enhances its sensitivity about 10x at night
- Accepts Infrared Light

24VAC/12VDC dual power design:

- Offers the flexibility of installation
- Ensures reliability

Main features:

- External adjustment controls for lens and On Screen Display (OSD)
- High Density 1/3" Sony EX-view CCD (960H)
- 700TVL High Resolution
- 6-50mm Variable Focal Length Lens
- Weatherproof IP68 NEMA Rating Optimized for Outdoor Use
- Secondary Video Output for Simple Installation & Maintenance
- 70ea Self Adjusting "Dynamic Intensity" IR LEDs
- E-WDR by ATR (Adaptive Tone Reproduction)
- 2-D noise reduction
- True Day/night by ICR
- Motion Detection
- Privacy Mask function
- OSD menu and camera ID
- Very low noise and superior picture quality
- Sensitivity of 0.003Lux (F1.2@40IRE)
- Automatic White Balance (ATW)
- Support C/CS mount DC Drive auto iris lens
- 300ft Night Observation Range
- Supply voltage: 24Vac/12Vdc Dual voltage

3. Supplied Items

- 1x VTC-IRE70/650 Long range IR Bullet Weatherproof camera
- 1x Sunshield panel with Fixing screw for Sunshield panel
- 1x 5mm Hex L-wrench (a)
- 1x 3mm Hex L-wrench (b)
- 4x Wall fixing screws (c) with 4x anchors (d)
- 1x Installation and Operating Instructions
- 1x Mounting template
- 1x Video Sub-out cable (e)

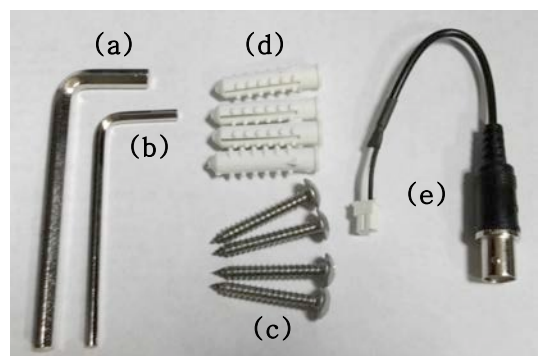

4. Part Names

4.1 Front view

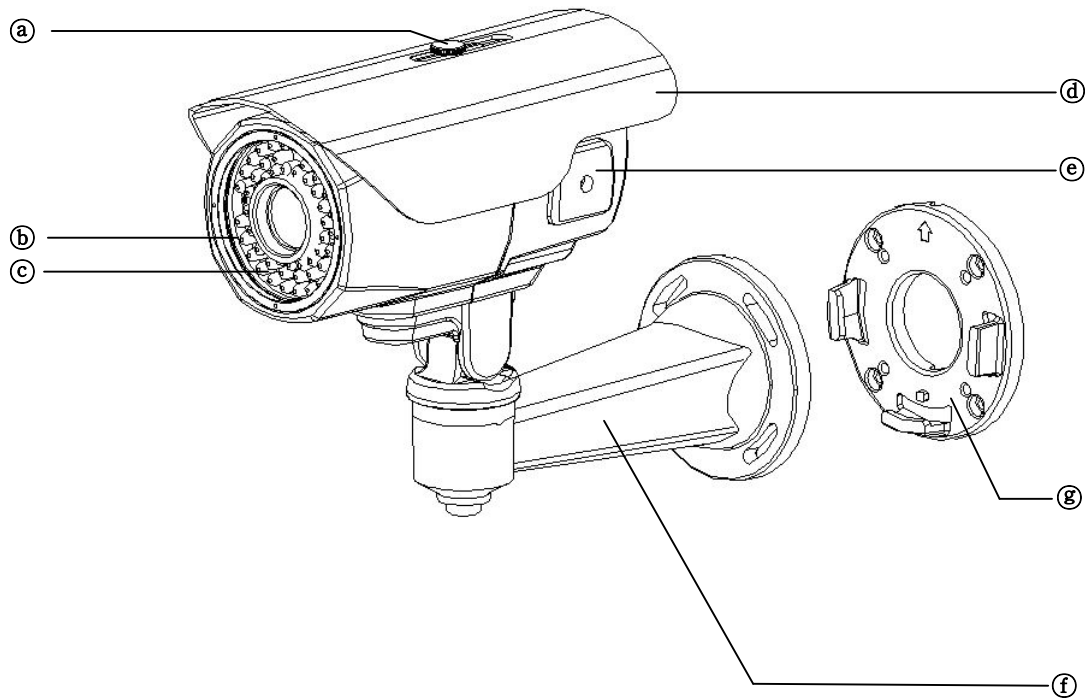

- Sunshield attachment thumb screw
- IR LED Panel
- Double Glass Window
- Sunshield
- OSD (On Screen Display Control) Cover
- Arm Assembly
- Mounting Bracket Foot

4.2 Rear side view

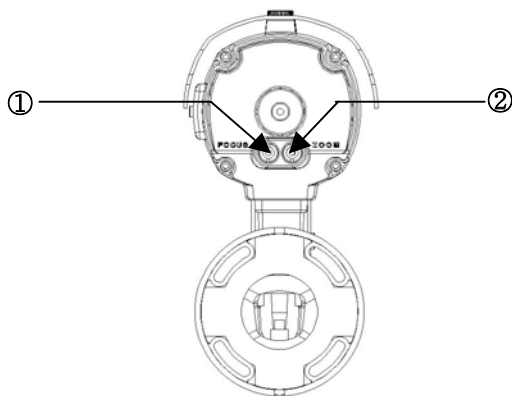

- Focus adjustment
- Zoom adjustment

5. Installation Instructions

- Make sure the power is not applied before installation.
- Once the camera is installed, you must first connect the low voltage (AC24V or DC12V). Then, plug the AC adapter into the AC outlets to avoid an improper reset and damage from a possible surge voltage.

5.1. Mounting the camera on the wall

- 1) Drill 4 holes into the wall or ceiling using the supplied template
- 2) Insert the anchors into the drilled holes
- 3) Match (foot mount holes) to the drilled holes
- 4) Affix the mounting bracket by using supplied screws

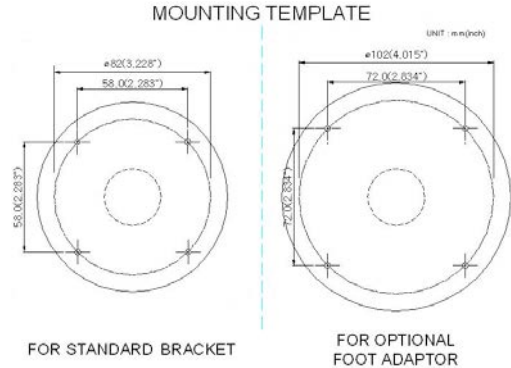

5.2. Power Supply Connections

The VTC-IRE70/650 can operate with either 24AC or 12VDC, dual voltage power.

It is required that the polarity-matched connection is made for 12VDC supply, otherwise IR LEDs, will not operate at night.

Primary and secondary grounds are completely isolated to avoid possible ground-loop problems.

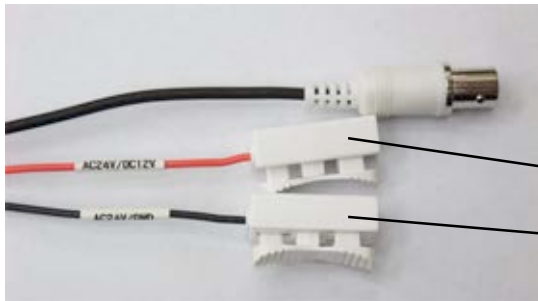

Clamp connectors of power input

AC24V/DC12V (RED WIRE)

AC24V/GND (BLACK WIRE)

6. SETUP Menu

6.1 In the Menu

The setup menu can be accessed and controlled with the OSD joy stick on the side of camera.

Five commands are available with the joy stick.



SYMBOL descriptions for joystick operation



1. ▲, ▼, ◀, ▶ - Denotes the direction of Joystick lever operation.
2. ● - Denotes "ENTER" by pressing straight down on the Joystick lever

In the menu, use ▲, ▼ to move menu, ◀, ▶ to change the settings and press ● to select or enter.

The **FACTORY DEFAULT** in this manual may **NOT** be the same as the default values set by the **FACTORY** due to feature improvements or customer requirements.
 To enter menu, press ● when MENU is not active.

6.2 MAIN menu

Follow the chart for submenu settings.

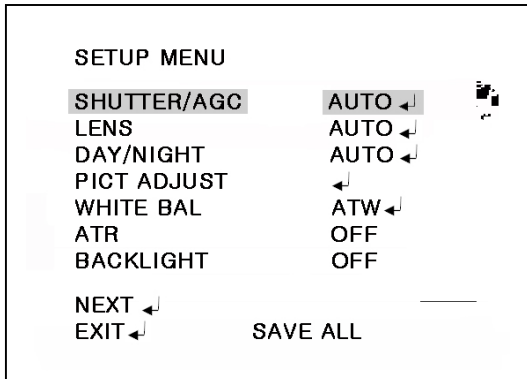

MAIN menu-1

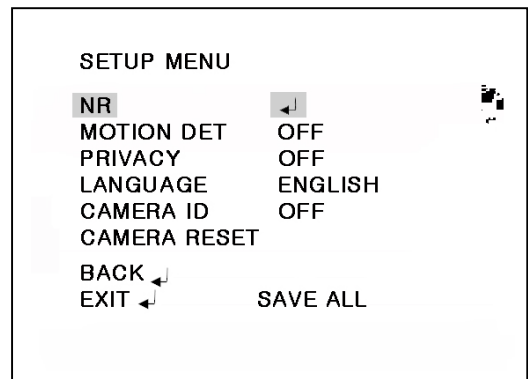

MAIN menu-2

6.2.1 MAIN menu-1

MAIN menu-1	Default	Descriptions
SHUTTER /AGC	AUTO	Sets the parameters related to the shutter mode and AGC for AUTO and MANUAL settings. See '6.3 SHUTTER/AGC menu' for details.
LENS	AUTO	Selects the lens type, AUTO or MANUAL. AUTO supports DC auto-iris lens only. See '6.4 LENS menu' for details.
DAY/NIGHT	AUTO	DAY/NIGHT mode for AUTO only with IR LED version. AUTO – Camera switches DAY from/to NIGHT automatically by the built-in light sensor. BURST, DELAY CNT, DAY→NIGHT, NIGHT→DAY can be set. See '6.5 DAY/NIGHT menu' for details.
PICT ADJUST	-	Sets MIRROR, BRIGHTNESS, CONTRAST, SHARPNESS, HUE or GAIN. See '6.6 PICT ADJUST menu' for details.
WHITE BAL	ATW	Sets ATW, PUSH, USER1, USER2, ANTI CR, MANUAL or PUSH LOCK. See '6.7 WHITE BAL menu' for details.
ATR	OFF	Sets ON/OFF for enabling/disabling ATR (Adaptive Tone Reproduction) compensation for the better dynamic range (E-WDR) of the image. See '6.8 ATR menu' to adjust the dynamic ranges.
BACKLIGHT	OFF	Selects BACKLIGHT mode out of OFF, HLC or BLC. Areas and gains for HLC and BLC are factory preset and not user adjustable.
NEXT		Moves to MAIN menu-2.
EXIT		Exits the setup menu. To save the changes, move cursor to 'SAVE ALL' and press ● button before exiting the setup menu
SAVE ALL		Saves all parameters by pressing ● button when cursor is on 'SAVE ALL'

6.2.2 MAIN menu-2

MAIN menu-2	Default	Descriptions
NR	-	Sets the noise reduction parameters for NR MODE and Y LEVEL, C LEVEL. See '6.9 NR menu' for details.
MOTION DET	OFF	Sets ON/OFF for enabling/disabling MOTION DET. See '6.10 MOTION DET menu' for the parameter settings.
PRIVACY	OFF	Sets ON/OFF for enabling/disabling PRIVACY. See '6.11 PRIVACY menu' for the parameter settings.
LANGUAGE	ENGLISH	Selects 1 out of 7 languages.
CAMERA ID	OFF	Sets ON/OFF for enabling/disabling of ID display. Factory default ID is Software version of camera. User programmed camera ID will be lost and restored with Factory default ID by CAMERA RESET. See '6.12 ID menu' for editing ID.
CAMERA RESET		Restores FACTORY DEFAULT. To save the restored parameters, move cursor to 'SAVE ALL' and press ● button before exiting the setup menu.
BACK		Returns to MAIN menu-1.
EXIT		Exits the setup menu. To save the changes, move cursor to 'SAVE ALL' and press ● button before exiting the setup menu
SAVE ALL		Saves all settings by pressing ● button when cursor is on 'SAVEALL'

6.3 SHUTTER/AGC menu

This menu explains how to control/select SHUTTER, AUTO IRIS and AGC to get the best image for high luminance and the low luminance according to the scene.

For example, to reduce the 'wash out' and extend the dynamic range for highlighted scene, you will use SHUTTER+AUTO IRIS in outdoor daylight. This mode may show color rolling or video level hunting problems in certain lighting condition such as fluorescent lights.

For Flickerless mode which reduces flickers by NTSC cameras under 50Hz light or PAL camera under 60Hz light, MAIN>SHUTTER/AGC>MANUAL>SHUTTER must be set to 1/100 (NTSC), 1/120 (PAL) and MAIN>SHUTTER/AGC>AUTO>MODE to AUTO IRIS. Normal shutter speed with an auto iris lens should be set to 1/60 (NTSC) and 1/50 (PAL) for the best sensitivity.

This is a complicated menu so please proceed with care when handling the Shutter.

To enter SHUTTER/AGC menu, press ● button at MAIN menu-1>SHUTTER/AGC.

AUTO SETUP	
HIGH LUMINANCE	
MODE	AUTO IRIS
BRIGHTNESS	 32
LOW LUMINANCE	
MODE	AGC
BRIGHTNESS	x0.50
RETURN ↵	

MANUAL SETUP	
MODE	SHUT+AGC
SHUTTER	1/50
AGC	6.00
RETURN ↵	

6.3.1 SHUTTER/AGC>AUTO SETUP menu

AUTO SETUP		Default	Descriptions
HIGH LUMINANCE	MODE	AUTO IRIS	<p>Sets the shutter mode from AUTO IRIS or SHUT+AUTO IRIS when MAIN>LENS>AUTO menu, but it is fixed to SHUT if in the MAIN>LENS>MANUAL menu.</p> <p>AUTO IRIS - Light level is controlled by an auto iris lens only. For proper auto iris operation, the auto iris operation mode in MAIN>LENS>AUTO>MODE must be set to AUTO.</p> <p>The shutter speed is fixed to the setting at MAIN>SHUTTER/AGC>MANUAL> SHUTTER. Set SHUTTER to 1/60 (NTSC) or 1/50 (PAL) for the best sensitivity unless it is in Flickerless mode.</p> <p>To set Flickerless mode, MAIN>SHUTTER/AGC>MANUAL>SHUTTER must be set to 1/100 (NTSC), 1/120 (PAL) and MAIN>SHUTTER/AGC>AUTO>MODE to AUTO IRIS.</p> <p>SHUT+AUTO IRIS- Light level is controlled by the combination of an auto iris lens and a shutter control to improve the highlight from wash-out and extend the dynamic range. Shutter speed can vary between 1/60 (1/50) ~ 1/10,000sec.</p> <p>This mode enhances the overall video quality of daylight but may show more smear over a bright spot light or may show color rolling or video level hunting under certain lighting conditions such as fluorescent lights.</p>
	BRIGHT-NESS	032	Adjusts the brightness of the image with an auto iris lens or a shutter speed control + an auto iris lens.
LOW LUMINANCE	MODE	AGC	Sets AGC to compensate the video level when the scene is dim.
	BRIGHT-NESS	x0.50	<p>Sets the brightness level which starts AGC from x0.25, x0.50, x0.75 and x1.0 of full video level.</p> <p>If set to x0.50, the camera will start AGC when the video level goes down below the 50% level.</p>

NOTICE: The setting AUTO IRIS at SHUTTER/AGC>AUTO SETUP>HIGH LUMINANCE MODE will be changed to SHUT+AUTO IRIS if MAIN menu-1>LENS is changed to MANUAL. As a result of this, the lens iris can NOT be fully opened when MAIN menu-1>LENS>AUTO IRIS> MODE is OPEN. This can be recovered by setting SHUTTER/AGC>AUTO SETUP>HIGH LUMINANCE MODE to AUTO IRIS.

6.3.2 SHUTTER/AGC>MANUAL SETUP menu

MANUAL SETUP	Default	Descriptions
MODE	SHUT +AGC	Compensates the video level by the manual shutter control and AGC.
SHUTTER	1/60 (1/50)	Sets the manual shutter to 1/60(1/50), 1/100(1/120), 1/250,1/500,1/1000, 1/2000, 1/4000 or 1/10000. Manual shutter is only useful when luminance is unchanged.
AGC	6.00	Sets AGC gain in dB. Higher gain compensates brighter but noise increases. Manual AGC can be set to 6, 12, 18, 24, 30, 36, 42 or 44.8dB.

6.4 LENS menu

To enter LENS menu, press ● button at MAIN menu-1>LENS>AUTO.

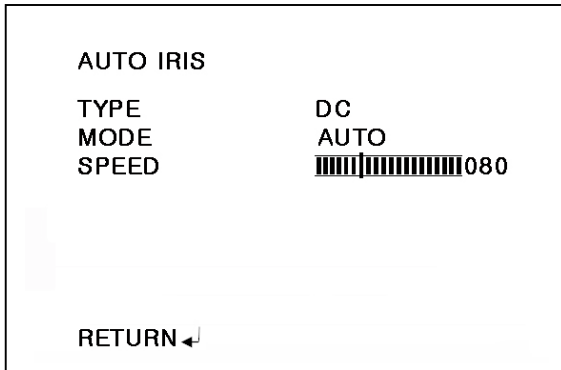

AUTO IRIS	Default	Descriptions
TYPE	DC	MUST BE SET TO DC ONLY. This camera does NOT support video type auto iris lens.
MODE	AUTO	AUTO – Lens iris is automatically controlled according to the scene's light level. OPEN – Lens is fully opened regardless of the light level. CLOSE – Lens is fully closed.
SPEED	080	Adjusts the iris control speed. The lower the value, the faster the speed. If the speed is too slow or fast, the iris control may be unstable.

6.5 DAY/NIGHT menu

To enter DAY/NIGHT menu, press ● button at MAIN menu-1>DAY/NIGHT.

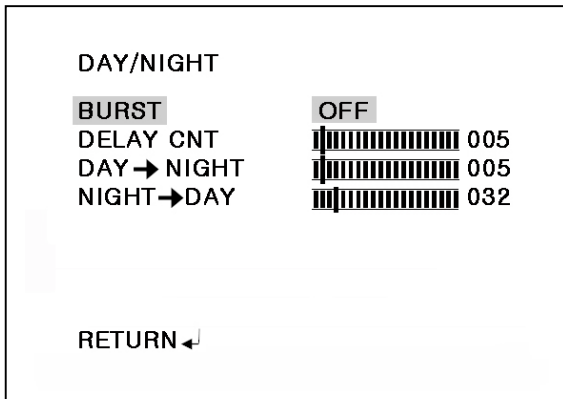

IMPORTANT ACTIVITY!!!

DAY->NIGHT and NIGHT->DAY operations must be examined and verified at the final installation.

Block the lens for a few seconds for NIGHT mode and release and let it return to DAY mode.

If camera stays at NIGHT mode for more than 10 seconds, decrease NIGHT→DAY THRES and repeat the fore-mentioned steps.

If the scene is too dim or the lens iris was adjusted too low (near close), it may not return to DAY.

DAY/NIGHT	Default	Descriptions
BURST	OFF	BURST determines whether a color burst signal is output or eliminated when the camera switches to B/W. If set to ON, the B/W video signal will contain a color burst signal and is compatible with the color equipment but shows the same resolution as color video. If set to OFF, the color burst signal is removed from B/W video and shows better resolution. However, compatibility problems may occur with the color equipment.
DELAY CNT	005	DELAY CNT is the time in seconds that the camera maintains its status before Day↔Night switches. DELAY can avoid the unwanted/frivolous switching due to short term lights such as light from a passing car.
DAY→NIGHT	005	DAY→NIGHT is a threshold level that determines whether or not to switch from DAY to NIGHT. A lower (higher) value makes the camera switch from Day to Night at a lower (higher) illumination. If it stays in Day (Color) mode at night time, increase DAY→NIGHT threshold value until it switches to Night. <u>Examine and verify Day/Night operation according to IMPORTANT ACTIVITY.</u> CAUTION If the gap between DAY→NIGHT and NIGHT→DAY is not big enough, camera may repeat Day↔Night switches.

NIGHT→ DAY.	3	<p>NIGHT→DAY is a threshold level that determines whether or not to switch from NIGHT to DAY. A lower (higher) value makes the camera switch from Night to Day at a lower (higher) illumination. If it stays in Night (B/W) mode at day time, decrease NIGHT→DAY threshold value until it switches to Day. <u>Examine and verify Day/Night operation according to IMPORTANT ACTIVITY.</u></p> <p>CAUTION If the gap between DAY→NIGHT and NIGHT→DAY is not big enough, camera may repeatedly switch from Day↔Night. If NIGHT→DAY is decreased from the Factory default, the same amount is recommended for DAY→NIGHT to avoid repeating DAY↔NIGHT unintentionally.</p>
----------------	---	--

6.6 PICT ADJUST menu

To enter PICT ADJUST menu, press ● button at MAIN menu-1>PICT ADJUST.

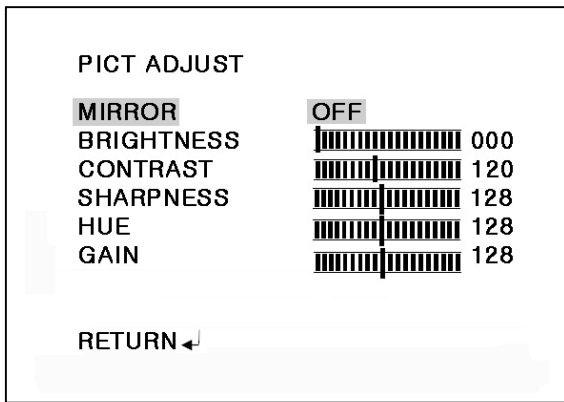

PICT ADJUST	Default	Descriptions
MIRROR	OFF	Picture will be flipped horizontally if it turns ON.
BRIGHTNESS	000	Increases or decreases the brightness of the picture. This is different from that of DC iris lens and simply increases or decreases the digital gain of video. Do not increase this too much, or the dynamic range for the highlight area will decrease.
CONTRAST	120	Increases or decreases the contrast of the picture.
SHARPNESS	128	Increases or decreases the sharpness of the picture. Too much sharpness can make the image appear harsh and will show more noise. It may also show line flicker at the edge of object in the picture.
HUE	128	Adjusts hue for NTSC version only
GAIN	128	Increases or decreases the color gain of the picture

6.7 WHITE BAL menu

White balance can be set to **ATW**, **PUSH**, **USER1**, **USER2**, **ANTI CR**, **MANUAL** or **PUSH LOCK**.

ATW (Auto Tracking White balance) and PUSH (Full pull-in) is continuously monitoring/analyzing the color temperature of the incoming light and correcting the white balance.

ATW limits the color temperature range to about 2,500°K~8,500°K to reduce the excessive compensation for a large object that has a single color.

PUSH has no limits between about 1,800°K~10,500°K, but it may over-compensate the white balance for a large object that has a single color.

In cases under 2,500°K such as halogen light, ATW may stop and if so, PUSH mode is recommended.

USER1 and **USER2** are a fixed white balance which is user-programmable by R-GAIN and B-GAIN and useful only for consistent/steady lighting.

ANTI CR (Anti Color Rolling) can reduce color rolling under fluorescent lighting when the camera operates in shutter control mode without an auto iris lens. (NTSC version only).

MANUAL white balance is a kind of fixed white balance that is user-programmable by B-GAIN, (R-GAIN will be automatically adjusted in accordance with B-GAIN) and useful only with consistent/steady lighting.

PUSH LOCK is a fixed white balance where the white balance is compensated only while ● button is pressed at MAIN>WHITE BAL>PUSH LOCK and finishes the white balance when ● button is released.

To enter ATW (MANUAL) menu, press ● button at MAIN **menu-1**>WHITE BAL>ATW(MANUAL).

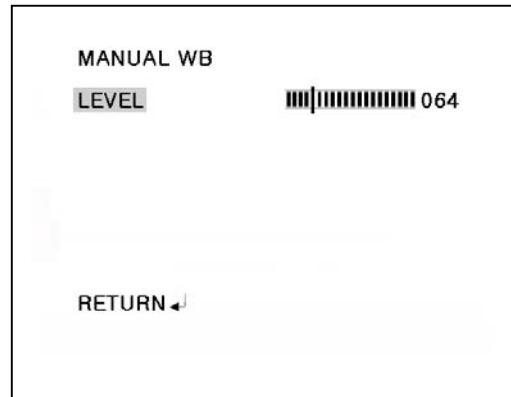
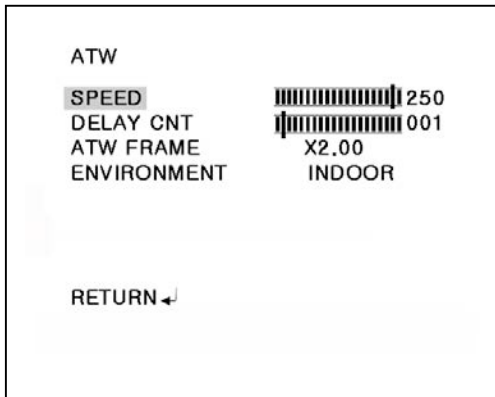

ATW	Default	Descriptions
SPEED	250	Sets the AWB compensating speed. Lower value makes AWB faster. CAUTION If AWB is too fast, it may produce color oscillation.
DELAY CNT	001	Adjusts the AWB compensation period to next update of AWB. The smaller value will update AWB more frequently.
ATW FRAME	X2.00	Determines the ATW range with respect to the fundamental range. A higher value than x1.00 will extend the ATW range at lower and higher color temperature.
ENVIRONMENT	INDOOR	Selects INDOOR or OUTDOOR. The ATW is optimized for limited applications. INDOOR - Optimized for Indoor installation and it compensates ATW for low color temperature such as incandescent lights. OUTDOOR - Optimized for outdoor sunlit applications and compensates ATW for high color temperature such as daylight.

MANUAL WB	Default	Descriptions
LEVEL	064	Adjusts the manual white balance by LEVEL, (B-GAIN).

6.8 ATR (Adaptive Tone Reproduction) Menu

The ATR feature improves the dynamic range and the visibility of the image by providing the optimal gradation compensation of the image in one field. This is achieved by two ways of image processing, luminance compression and contrast enhancement, so that the tone can be enhanced in highlighted and dark areas.

To enter ATR menu, press ● button at MAIN menu-1>ATR.

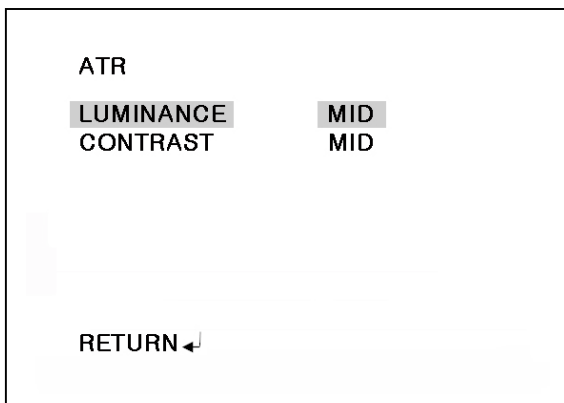

ATR	Default	Descriptions
LUMINANCE	MID	Compresses the highlighted areas and enhances the dark areas so that the entire image can converge toward the medium level. LOW will compensate minimally and HIGH will be averaging the image more. With a HIGH setting, the image may look less contrastive and noise may increase in the dark area.
CONTRAST	MID	Adjusts the strength of the image contrast. If set to too high, the dark area may lose detail and the high luminance area may saturate.

6.9 BACKLIGHT menu

To enter BACKLIGHT menu, press ● button in MAIN menu-1>BACKLIGHT.

The Backlight Compensation – BLC – function is used to brighten an image in the foreground with a highly lit area behind it such as sunlight, limiting the affect of silhouetting.



The Highlight Compensation – HLC – function is used to black out highlighted areas that may blind the camera, in order to enable a clear visual image of objects, such as the license plates of an oncoming vehicle or other objects that may be obstructed by headlamps.



6.10 NR menu

To enter NR menu, press ● button at MAIN menu-2>NR.

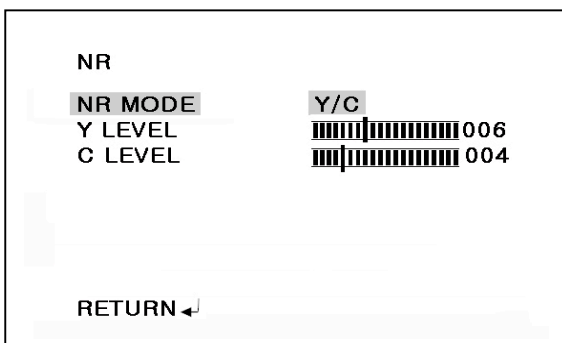

NR	Default	Descriptions
NR MODE	Y/C	Selects OFF, Y, C or Y/C, which noise reduction is performed with.
Y LEVEL	006	Indicates the noise reduction strength for the luminance signal. A higher value performs a stronger noise reduction, which makes the image less sharp.
C LEVEL	004	Indicates the noise reduction strength for the chrominance signal. A higher value performs a stronger noise reduction and makes the image less sharp.

6.11 MOTION DET menu

Up to 4 motion detection areas are available and each area is programmable in size and location. The motion is displayed by means of blocks when MAIN **menu-2**>MOTION DET and MOTION DET>BLOCK DISP are ON.

To enter MOTION DET menu, press ● button at MAIN **menu-2**>MOTION DET>ON.

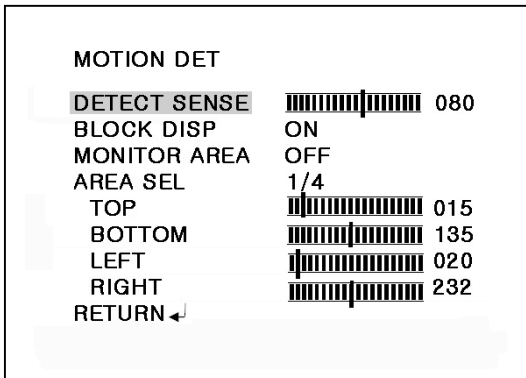

MOTION DET	Default	Descriptions
DETECT SENSE	080	Adjusts the sensitivity for detecting motion. Higher value is more sensitive.
BLOCK DISP	ON	Enables or disables display blocks for the area where motion is detected.
MONITOR AREA	OFF	Displays four motion windows as programmed in sizes and positions.
AREA SEL	1/4	Selects one of AREA1~AREA4 to be adjusted. TOP (BOTTOM) - □ button moves up and □ button moves down the top (bottom) border of the selected window at AREA SEL. LEFT (RIGHT) - □ button moves left and □ button moves right the left (right) border of the selected window at AREA SEL

6.12 PRIVACY menu

Up to 8 privacy areas are available and each area is programmable in size and location. The number of privacy areas is limited to four when MOTION DET>MONITOR AREA is ON. The privacy areas are masked with the color selected in PRIVACY>COLOR.

To enter PRIVACY menu, press ● button at MAIN **menu-2**>PRIVACY>ON.

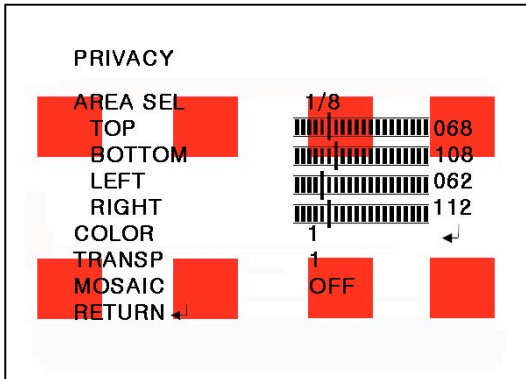

PRIVACY	Default	Descriptions
AREA SEL	1/8	Selects one of AREA1~AREA8 to be adjusted. TOP (BOTTOM) - □ button moves up and □ button moves down on the top (bottom) border of the selected window at AREA SEL. LEFT (RIGHT) - □ button moves left and □ button moves right on the left (right) border of the selected window at AREA SEL.
COLOR	1	Sets one of 8 colors for the selected mask window at AREA SEL.
TRANSP	1.00	Transparency rate for the mask can be adjusted. 0.00 - Mask is fully transparent and not visible. 0.50 - Mask is 50% transparent. 0.75 - Mask is 25% transparent. 1.00 - Mask is not transparent.
MOSAIC	OFF	Enables or disables the mosaic effect for the selected mask window at AREA SEL.

6.13 LANGUAGE menu

Seven languages, ENGLISH, JAPANESE, DEUTCH (German), FRANCAIS (French), RUSSIAN, PORTUGUES (Portuguese) and ESPANOL (Spanish), are available with this camera.

6.14 CAMERA ID menu

Up to 40 characters can be input for camera ID.

To enter CAMERA ID menu, press ● button at MAIN menu-2>CAMERA ID.

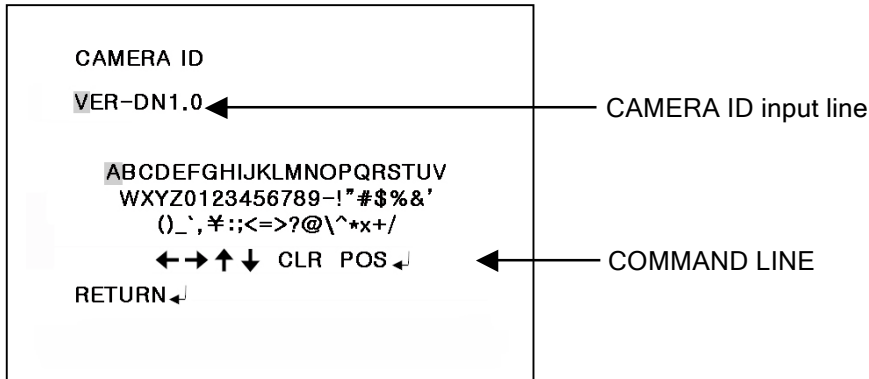

Use ▲, ▼, □, □ buttons to move a block cursor in the character table and press ● button to input the selected character.

To move the character input position on CAMERA ID input line, move a cursor to ←→ on COMMAND LINE and press ● button on ← or →.

To clear CAMERA ID input line, move a cursor to CLR on COMMAND LINE and press ● button.

To set the location of CAM TITLE to be displayed on the monitor, move a cursor to POS and press ● button and then menu disappears and CAMERA ID will be displayed on the monitor.

Move CAMERA ID by using ▲, ▼, □, □ buttons and press ● button to fix.

Menu will appear again.

To finish CAM TITLE menu, press ● button on RET on command line.

6.15 CAMERA RESET

Camera loads Factory defaults.

To save them, go to SAVE ALL and press ● button.

6.16 EXIT

Exits SETUP MENU and returns to the normal display

7. Specifications

Model Name	VTC-IRE70/650
Image Device	1/3" High Density Sony EX-VIEW CCD & Effio-E DSP (960H)
Effective Pixels	976(H) x 494(V)
Resolution	700 TV lines
Minimum illumination	0.0035Lux / F1.2 (0 Lux with IR LEDs ON)
Infrared LEDs	70 840nm IR LEDs
IR Distance	Over 300 Feet
Beam Spread	21 Pieces at 40 degrees + 49 Pieces at 50 degrees
Day/Night	True Day/Night by ICR
S/N Ratio	More than 50dB with AGC OFF at 50IRE
Electronic Iris	1/60 to 1/100,000 sec.
Built-In Lens	6-50mm DC A/I, Switched IR Cut Filter D/N Lens
Light Compensation	HLC (Highlight Compensation) / BLC (Backlight Compensation)
Iris Mode	DC Drive Iris Control (Internally Fixed)
Gain Control	Auto
White Balance	1,800~10,500°K Automatic Tracking
Video Output	VBS 1Vpp +/- 10%, 75ohm
TV System	2:1 Interlace
Scan Frequency	59.94Hz(V), 15.734Khz(V)
Synchronization	Internal/Line Lock (Default: Internal)
Noise Reduction	2DNR
E-WDR	YES by ATR (Adaptive Tone Reproduction)
Motion Detection	YES (24x 16 BLOCK ALARM AREA)
Privacy Mask	Up to 8 Programmable Mask Areas
Flicker Reduction	Yes
OSD Language	English, Japanese, German, French, Russian, Portugese, Spanish
Water Resistance	IP68
Construction	Aluminum Housing
Power Source	12VDC/24VAC (Dual Voltage)
Power Consumption	IR ON: 800mA (12VDC) / 820mA (24VAC) / IR OFF: 110mA (12VDC) / 120mA (24VAC)
Operating Conditions	-4°F~+122°F (-20°C~+50°C) / 85% RH Max
Length	11.25" (286mm)
Width	Camera: 3.6" (91mm) / Camera w/Sun Shield: 4.7" (119mm)
Height	8.5" (216mm)
Weight	4.4 lbs. (1996g)

- Design and specifications are subject to change for product improvements without prior notice.

8. Dimensional Drawings

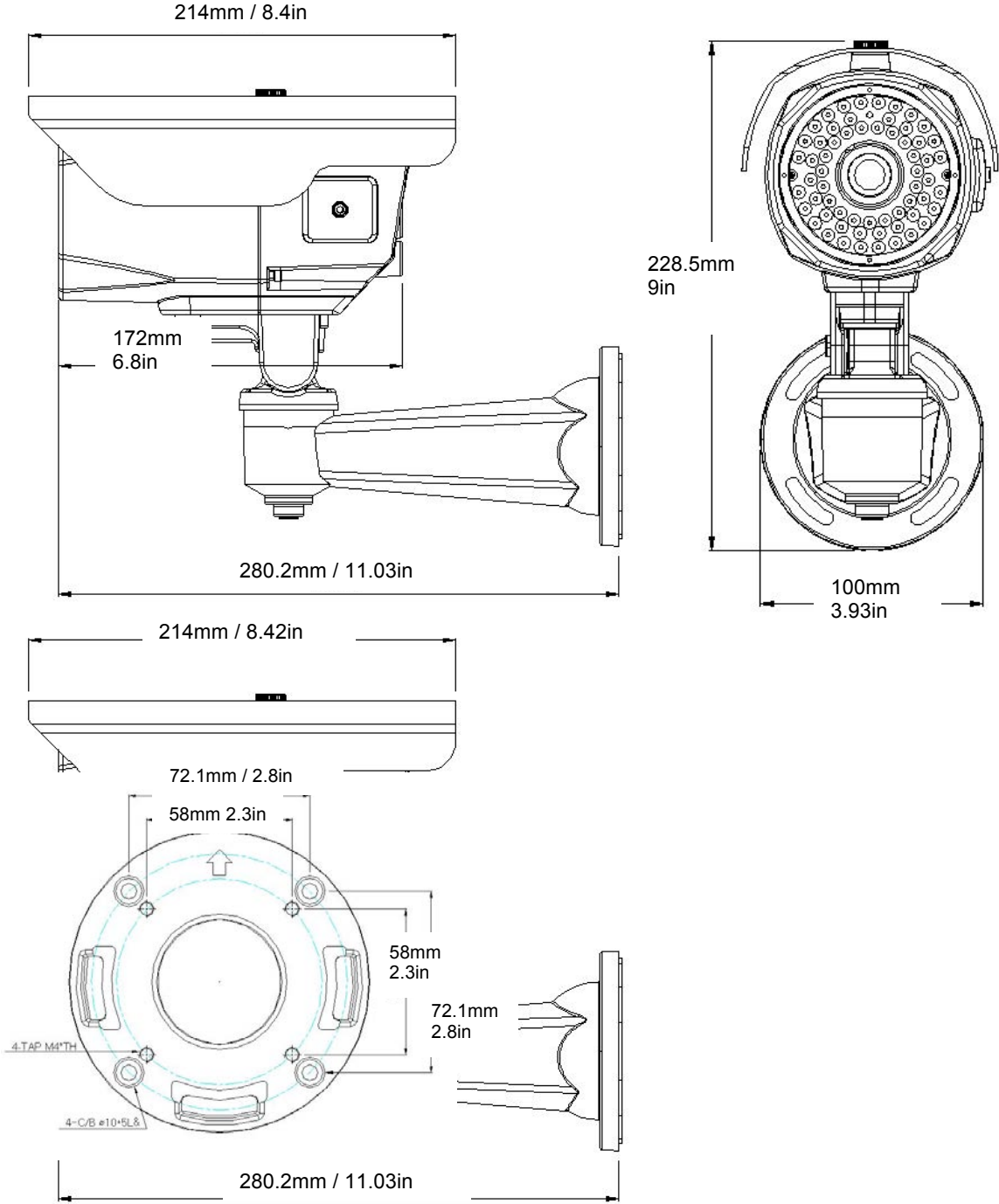

VITEK LIMITED PRODUCT WARRANTY

VITEK products carry a three (3) year limited warranty. VITEK warrants to the purchaser that products manufactured by VITEK are free of any rightful claim of infringement or the like, and when used in the manner intended, will be free of defects in materials and workmanship for a period of three (3) years, or as otherwise stated above, from the date of purchase by the end user. This warranty is non-transferable and extends only to the original buyer or end user customer of a VITEK Authorized Reseller.

The product must have been used only for its intended purpose, and not been subjected to damage by misuse, willful or accidental damage, caused by excessive voltage or lightning.

The product must not have been tampered with in any way or the guarantee will be considered null and void.

This guarantee does not affect your statutory rights.

Contact your local VITEK Reseller should servicing become necessary.

VITEK makes no warranty or guarantee whatsoever with respect to products sold or purchased through unauthorized sales channels. Warranty support is available only if product is purchased through a VITEK Authorized Reseller.

Visit www.vitekctv.com to register your product warranty and receive periodic updates.



28492 CONSTELLATION ROAD VALENCIA, CA 91355
WWW.VITEKCCTV.COM | 888-VITEK-70